

## 3.1.9.2 HGL

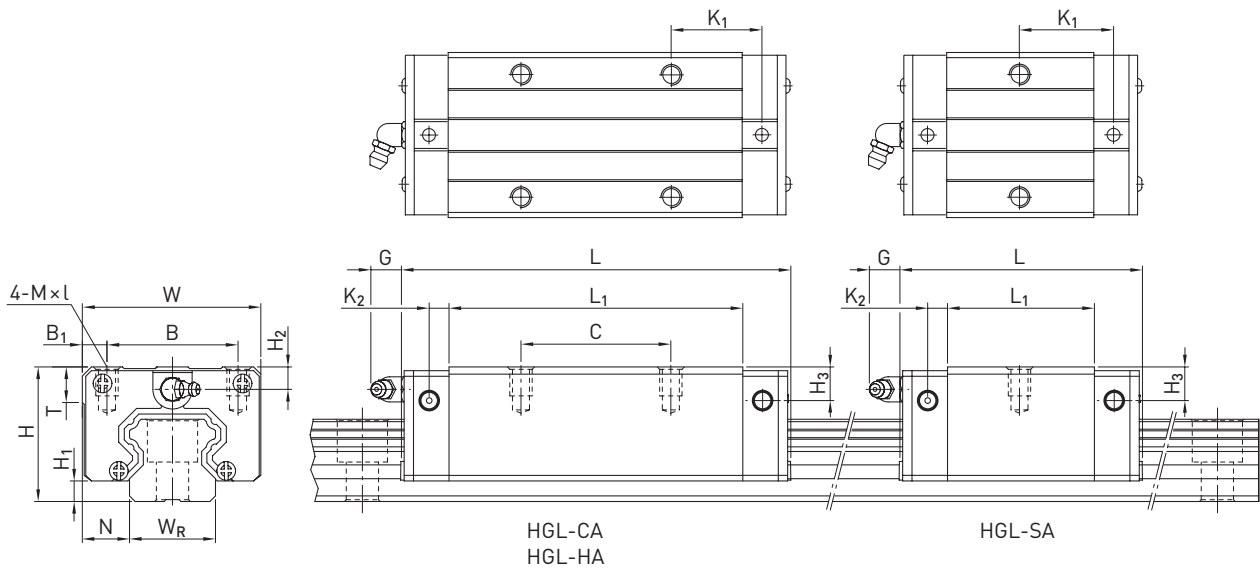

Table 3.7 Dimensions of the block

| Series/size | Installation dimensions [mm] |                |      | Dimensions of the block [mm] |    |                |    |                |                     |                |                |      |          |      |                |                | Load ratings [N] |                | Weight [kg] |
|-------------|------------------------------|----------------|------|------------------------------|----|----------------|----|----------------|---------------------|----------------|----------------|------|----------|------|----------------|----------------|------------------|----------------|-------------|
|             | H                            | H <sub>1</sub> | N    | W                            | B  | B <sub>1</sub> | C  | L <sub>1</sub> | L                   | K <sub>1</sub> | K <sub>2</sub> | G    | M × l    | T    | H <sub>2</sub> | H <sub>3</sub> | C <sub>dyn</sub> | C <sub>0</sub> |             |
| HGL15CA     | 24                           | 4.3            | 9.5  | 34                           | 26 | 4.0            | 26 | 39.4           | 61.4                | 10.00          | 4.85           | 5.3  | M4 × 4   | 6.0  | 3.95           | 3.7            | 14,700           | 23,470         | 0.14        |
| HGL25SA     | 36                           | 5.5            | 12.5 | 48                           | 35 | 6.5            | —  | 38.2           | 64.2                | 23.20          | 6.00           | 12.0 | M6 × 6   | 8.0  | 6.00           | 5.0            | 26,930           | 36,560         | 0.32        |
| HGL25CA     |                              |                |      |                              |    |                | 35 | 58.0           | 84.0                | 15.70          |                |      |          |      |                |                | 34,900           | 52,820         | 0.42        |
| HGL25HA     |                              |                |      |                              |    |                | 50 | 78.6           | 104.6               | 18.50          |                |      |          |      |                |                | 42,200           | 69,070         | 0.57        |
| HGL30CA     | 42                           | 6.0            | 16.0 | 60                           | 40 | 10.0           | 40 | 70.0           | 97.4 <sup>1)</sup>  | 20.25          | 6.00           | 12.0 | M8 × 10  | 8.5  | 6.50           | 10.8           | 48,500           | 71,870         | 0.78        |
| HGL30HA     |                              |                |      |                              |    |                | 60 | 93.0           | 120.4 <sup>2)</sup> | 21.75          |                |      |          |      |                |                | 58,600           | 93,990         | 1.03        |
| HGL35CA     | 48                           | 7.5            | 18.0 | 70                           | 50 | 10.0           | 50 | 80.0           | 112.4               | 20.60          | 7.00           | 12.0 | M8 × 12  | 10.2 | 9.00           | 12.6           | 64,600           | 93,990         | 1.14        |
| HGL35HA     |                              |                |      |                              |    |                | 72 | 105.8          | 138.2               | 22.50          |                |      |          |      |                |                | 77,900           | 122,770        | 1.52        |
| HGL45CA     | 60                           | 9.5            | 20.5 | 86                           | 60 | 13.0           | 60 | 97.0           | 139.4               | 23.00          | 10.00          | 12.9 | M10 × 17 | 16.0 | 8.50           | 20.5           | 103,800          | 146,710        | 2.08        |
| HGL45HA     |                              |                |      |                              |    |                | 80 | 128.8          | 171.2               | 28.90          |                |      |          |      |                |                | 125,300          | 191,850        | 2.75        |
| HGL55CA     | 70                           | 13.0           | 23.5 | 100                          | 75 | 12.5           | 75 | 117.7          | 166.7               | 27.35          | 11.00          | 12.9 | M12 × 18 | 17.5 | 12.00          | 19.0           | 153,200          | 211,230        | 3.25        |
| HGL55HA     |                              |                |      |                              |    |                | 95 | 155.8          | 204.8               | 36.40          |                |      |          |      |                |                | 184,900          | 276,230        | 4.27        |

<sup>1)</sup> 98.8 for type SE

<sup>2)</sup> 121.8 for type SE

For dimensions of the rail, see Page 41, for standard as well as optional lubrication adapter, see Page 150.