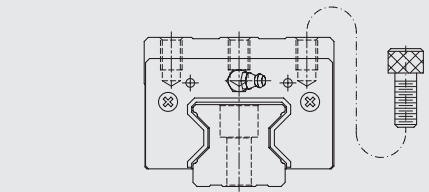
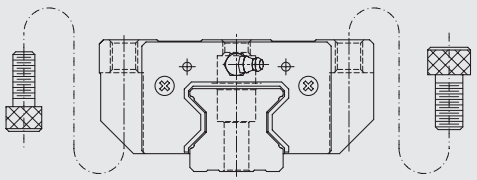

Linear guideways

CRG series

3.7.2 Block types

HIWIN offers block and flange blocks for its linear guideways. Due to the low installation height and the larger mounting surface, flange blocks are better suited for large loads.

Type	Series/size	Layout	Height [mm]	Typical applications
Square type	CRGH-CA CRGH-HA		28 - 90	<ul style="list-style-type: none"> ○ Automation technology ○ Transport technology ○ CNC machining centres ○ High performance cutting machines ○ CNC grinding machines ○ Injection moulding machines ○ Portal milling machines
Flange type	CRGW-CC CRGW-HC		24 - 90	<ul style="list-style-type: none"> ○ Machines and systems with high required rigidity ○ Machines and systems with high required load ratings ○ Spark erosion machines

3.7.3 Profile rail type

Profile rail with standard fastening from above.

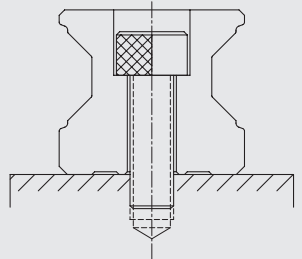
Fastening from above

CRGR_R