

Linear guideways

CG series

3.2.9.2 CGL

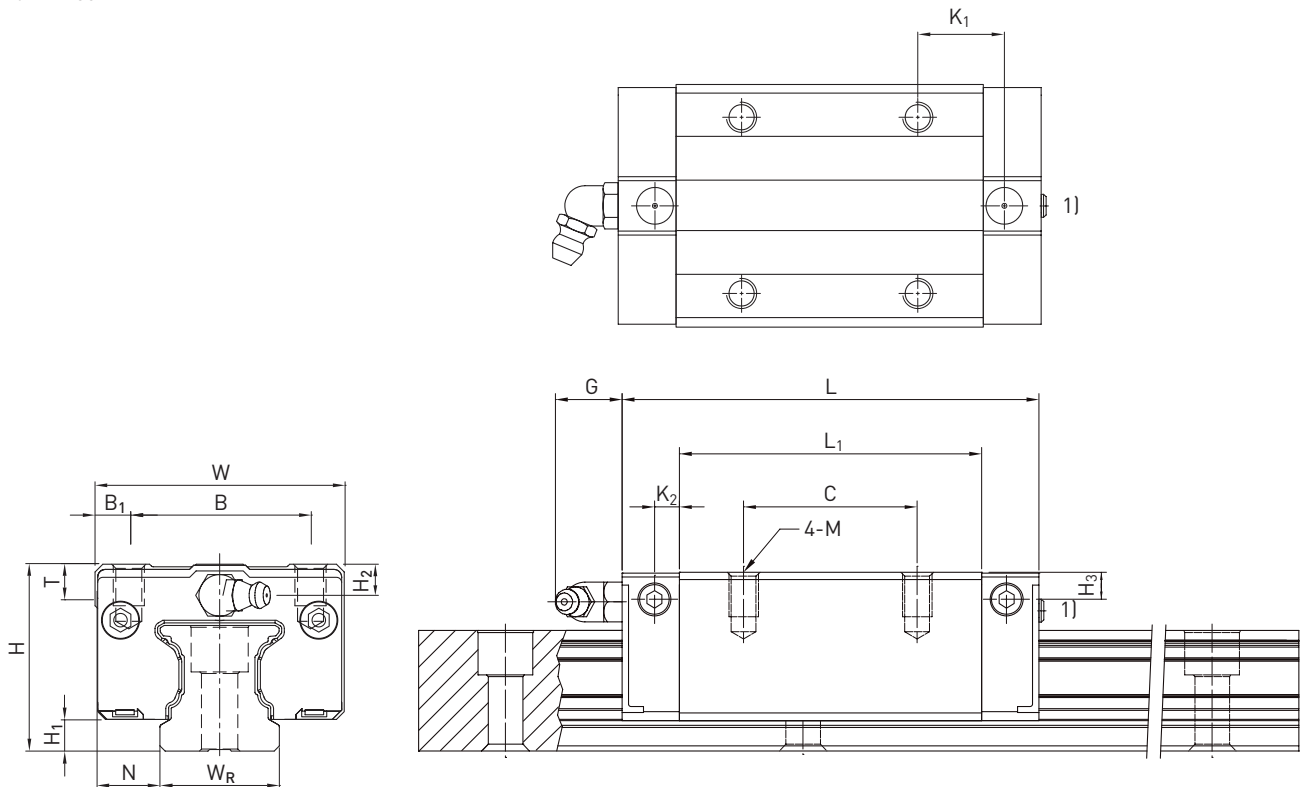

Table 3.25 Dimensions of the block

Series/size	Installation dimensions [mm]			Dimensions of the block [mm]													Load ratings [N]		Weight [kg]
	H	H ₁	N	W	B	B ₁	C	L ₁	L	K ₁	K ₂	G	M × l	T	H ₂	H ₃	C _{dyn}	C ₀	
CGL15CA	24	4.1	9.5	34	26	4.0	26	39.6	58.2	10.8	4.25	6.0	M4 × 6	6.0	3.8	3.8	14,700	19,520	0.11
CGL25CA	36	6.1	12.5	48	35	6.5	35	61.0	84.0	17.4	5.00	12.0	M6 × 8	8.0	6.0	5.5	34,960	43,940	0.37
CGL25HA							50	78.4	101.4	18.6							40,500	54,080	0.47
CGL30CA	42	7.0	16.0	60	40	10.0	40	69.0	97.4	19.75	8.70	12.0	M8 × 10	9.5	6.7	7.0	46,000	55,190	0.61
CGL30HA							60	91.5	119.9	21.0							58,590	78,180	0.82
CGL35CA	48	7.6	18.0	70	50	10.0	50	79.0	111.4	22.6	7.00	12.0	M8 × 13	10.2	9.0	7.0	61,170	79,300	0.93
CGL35HA							72	103.4	135.8	23.8							77,900	112,340	1.22
CGL45CA	60	9.7	20.5	86	60	13.0	60	97.2	137.6	23.0	8.70	12.9	M10 × 17	16.0	8.5	8.1	98,430	112,660	1.72
CGL45HA							80	133.6	174.0	31.2							125,580	159,600	2.39

For dimensions of the rail, see Page 58, for standard as well as optional lubrication adapter, see Page 150.

¹⁾ Flat head screw protrudes 1 mm in all sizes.